

From the HoD's desk



PUBLISH, INNOVATE AND SUCCEED

Welcome to our third news letter. This time we want to share with you the latest incidents in the field of electronics and instrumentation. Apptronics offers you opportunity to publish articles. Writing and publishing will not only help you to keep abreast with the latest research news and findings but also to develop your own comprehension and analytical skills.

Further it is a way of thinking, examining critically the various aspects of your day to day professional work, understanding and formulating guiding principles that govern a particular procedure and developing new theories for the enhancement of your professional practice. Also it is a habit of questioning what you do and a systematic examination of the observed information to find answers with a view to institute appropriate changes for a more effective professional practice.

In today's world we can benefit from resources all around and perform better in our career by contributing to research bulletin and taking up small research projects.

Congratulations to the entire AEI faculty and the editorial board for making a good start in this endeavor.

Contents

Orange peel to clean up dirty water	Subhija E N
DSP based motion control system	Sreejith K R
MPEG1 Audio compression	Meena V
Light to control Proteins	Prasanth P Menon
Magnetic Separator	Keerthi, Kuruvilla, Robin

Published by HOD, AEI, Rajagiri School of Engineering and Technology, Kochi- 682039.
For internal circulation only

ORANGE PEEL TO CLEAN UP DIRTY WATER

Nowadays, the main cause of environmental pollution is the colored industrial waste water. This poses a serious problem in our country, as India is rich in industries. Industrial waste water discolors waterways as well as blocks sunlight required by plant species in the water, for photosynthesis. Research is being carried out to solve this problem. Researchers in Algeria have discovered that nothing more sophisticated than orange peel could be used to remove acidic dyes from industrial effluent. Synthetic dyes are extensively used by industries including dye houses, textile dyers and color photography. It is also used as an additive in petroleum products.

Benaïssa Houcine of the Laboratory of Sorbent Materials and Water Treatment found a solution for this problem. We are commonly using chemical treatment to purify industrial water. But Benaïssa Houcine found out that the a common agricultural and food industry byproduct, orange peel, can act as an absorbent for the removal of four acid dyes from simulated samples of polluted water. He tested and found out that one gram of orange peel could absorb strong dyes including Nylosane Blue, Erionyl Yellow, Nylomine Red and Erionyl Red between 40 and 70 milligrams. Orange peel has a considerable potential for the removal of dyes from aqueous solutions over a wide range of concentrations. Orange peel may be used as a low-cost, natural and abundant source for the removal of dyes, and it may be an alternative to more costly materials. It may also be effective in removing other harmful or undesirable species present in the waste effluents. Researchers are working on identifying the biochemical sites within the orange peel to which the dye molecules stick during absorption.

-Subhija E. N.

DSP BASED MOTION CONTROL SYSTEM (JOURNAL REVIEW)

An interesting article, providing valuable information regarding DSP(Digital Signal Processor) based motion control systems, is presented by *Seema .S.Sheth, Dipanjan Jana, O.P. Joshi and S.M. Oak*. The authors implemented the system in a CNC (Computer Numerical Controller) machine. Texas TMS 320 LF 2407 DSP processor with 32k flash is used in this system. TMC 320LF2407 is a 16 bit processor with inbuilt PWM unit, A/D converter and microcontroller features. Integrated Development Environment provided by “code composer studio” makes program verification easy.

With this system, the CNC machine’s speed and position can be controlled simultaneously with high degree of accuracy. An ordinary PC and ps/2 keyboard can be used as input device. The user can program the system through the keyboard. An LCD display in the system enables display of the status of the CNC machine, the set point and any error message. Speed control of the system is designed for accelerating mode, steady state mode, and decelerating mode. The control algorithm is realized by a PID (Proportional Integral Derivative) controller. The authors have claimed a promising result from this project. To get more information on hardware configuration of the system, overall response of the system, PID control algorithm, processor details and possibilities of extension, please refer: *Journal of Instrument Society of India 38(2), Page no: 137-144.*

- Sreejith K.R.

Major events in the Department of Applied Electronics and Instrumentation (Abhiyantriki 2008)



BEST MANAGER CONTEST
George Thomas (S7 AEI) bagged the first prize



PROJECT EXHIBITION
Nixon, Ajay and Sebin (S3 AEI) won the II prize

MPEG1 AUDIO COMPRESSION

Let us continue our discussion on MPEG1. In this issue of the bulletin, we will go through details of the audio and the conformance testing of MPEG1.

MPEG1 Layer 3(MP3) provides higher quality audio compared to layers 1 & 2, at low bit rates of around 128k bits/sec for stereo. MPEG1 audio works for mono (single channel) and stereo (2 channels) audio signals. The other possible operating modes are dual channel and joint stereo (intensity stereo or mid/side stereo). It also supports signals with sampling frequency of 32 kHz, 44.1 kHz and 48kHz. The bit rates range from 32k bits/sec to 128k bits/sec. Different frames of audio can have different bit rate. A frame is one unit of audio for a fixed duration.

The encoder does perceptual encoding. It mainly uses *auditory masking* property. Audio masking is the property of human auditory system by which a sound consisting of mainly one frequency will mask quieter frequencies around it, and make those frequencies inaudible. The block diagrams of a perceptual encoder and decoder are given below.

Filter bank separates out the spectral components in the input signal using 32 subbands. It uses hybrid bank, cascades poly phase filter bank and MDCT (Modified Discrete Cosine Transform).

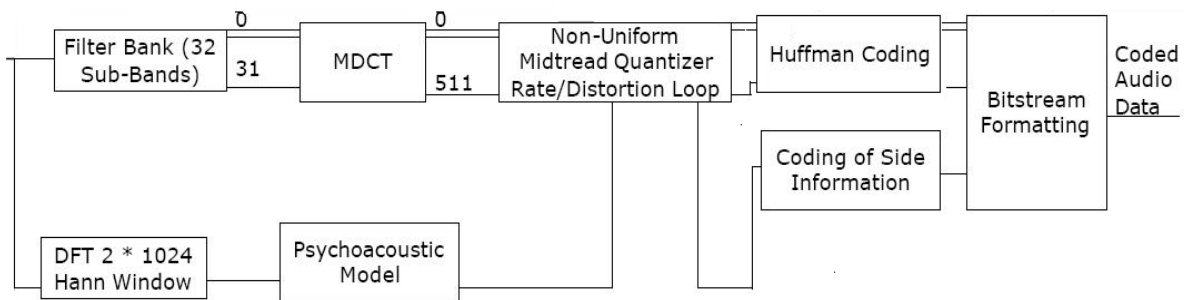

Perceptual model is also called psycho acoustic model. It looks for the masking threshold and bands that are not audible to human ear. Output of this block is a set of values for the threshold in each coder partition.

Coder partitions are critical bands of human hearing. In quantization stage, data bits are allocated by an MP3 encoder such that both the bitrate and masking requirements are satisfied.

Quantization noise is restricted to below masking threshold. Quantized values are then coded by Huffman coding. Different Huffman tables can be used for different components of the spectrum. Encoding process adds a mandatory header per frame (every 24ms for 48 kHz). Header contains information like sync word, bit rate, sampling frequency, layer number, coding mode & copy protection.

MPEG1 standard specifies only the data representation and maximum deviation of the decoded signal from that generated by the reference decoder which uses 'double' precision arithmetic accuracy. It gives no guarantee on the quality of the encoded stream. Implementation using fixed point arithmetic should ensure that the deviation of the decoded signal is less than the maximum specified in the section of the standard which talks about compliance.

Codec quality is measured by listening tests, simple objective techniques & perceptual measurement techniques. Listening tests give maximum stress to the encoder and measures the performance. i.e. some selected signals which are most difficult to encode are passed to the encoder, and its performance tested.

Perceptual quality measurement technique is done as per recommendations from ITU-R task group10/4, and is called perceptual evaluation of audio quality.

The quality of MP3 audio is further improved by using AAC in MPEG2. It gives 50% more compression efficiency compared to MP3 encoding.

-Meena

The wisest person is not the one who has the fewest failures but the one who turns failures to best account.

Richard R.Grant

LIGHT TO CONTROL PROTEINS

It was recently discovered that light can be used for controlling certain proteins that act as catalysts in biochemical reactions. A team of researchers from the University of Texas and Penn State are carrying out further research on this discovery.

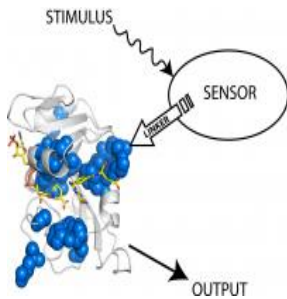

A hybrid protein was formed by inserting a light-sensing protein from an oat plant into an enzyme (a type of protein that catalyzes biochemical reactions) extracted from the bacterium *E. coli*. After the fusion, they studied that the activity of the enzyme could be stimulated by focusing a light on the light-sensing protein, also called by the scientists as 'domain'. This technology works like a light switch. i.e., the enzyme's activity increases when light is shone on the light-sensing protein, and by taking the light off, the enzyme's activity decreases. While designing the hybrid protein, a number of factors were taken into consideration. First factor is the shape of the protein referred to as its conformation. Without the proper conformation, protein would not respond to light. Another important factor considered was the proper location on the enzyme into which the light-sensing protein from the oat plant has to be inserted. The switch worked only when the scientists attached the light-sensing domain to the enzyme at a particular point. When the molecule was attached to other locations on the enzyme, the light switch did not work. It indicates that a unique network is active at that site, through which signals responding to light are transmitted.

Scientists used a computational algorithm called the Statistical Coupling Analysis (SCA), for locating the successful site, among more than a hundred different possibilities. The future research of the team is focusing on how the signal, triggered by the light, is transmitted from the light-sensing domain to the enzyme. This technology could be efficiently utilized in multiple ways, even to deactivate some disease causing proteins in the human cells. The team's results have appeared in the issue of the journal *Science* dated 17th October. This research was funded by the Defense Advanced Research Projects Agency (DARPA).

Prasanth P Menon

MAGNETIC SEPARATOR

We all know that magnet attracts magnetic particles. This phenomenon was utilized by us in our experiment. Our aim is to separate magnetic particles according to their size. For that, we need an intermittent magnetic field. So we decided to generate this field electrically by passing an impulse current to iron rods. When current passes through the rod, magnetic field is generated and when impulse stops the field vanishes.

When magnetic field is applied, particles of various sizes kept below the magnet at a distance, get attracted to various heights based on their size. Lighter particles move closer to the magnet than the heavier ones. When field is removed, all particles fall down due to gravitational force. During the return motion, we "catch" the finer particles by placing a non-conducting material in their path. This height may be adjusted according to the fineness we require.

We faced a few problems in the realization of this set up. Our aim was to make a prototype of the separator. The magnet we used initially generated a field that was very small compared to what we expected and what we needed. The generated field could lift fine particles to nearly 3-4 cms. Another problem that came across our way was the height. We didn't get sufficient height to separate out different sized particles. The particles we got were almost of the same size. Thus within 3-4 cms, they were all seen at almost the same height. We could not clearly make out the separation. We were only partially successful. But we hope that by increasing the magnetic field, possibly by passing more current, we can get a better efficiency for our instrument.

Keerthi, Kuruvilla, Robin (S3 AEI)

❖ u r i o s i t y

o Recently M&M introduced Scorpio
r Mhawk with tyre pressure monitoring
n system. How is pressure monitoring
e done in real time? What are the
r challenges involved?

First correct answer will win a small prize
Answer to the question in the previous issue

❖ u r i o s i t y

o
r
n
e
r



The time difference is equal to the time difference between GMT and IST.